

Technical data sheet

CRF9-T-FC03B

Touch Button Proportional Fan Coil Thermostat

Description

The Fan Coil Thermostat (CRF9-T-FC03B) has been designed for individual room temperature control in commercial, industrial and residential buildings.

The Fan Coil Thermostat comes with BACnet communication.

The thermostat has 1 Inputs (1 NTC10k, 1 dry contact, N/O occupancy contact) available.

The Power supply is 230 VAC.



Order Code	2/4 Pipe FCU	Communication	Output	Inputs
• CRF9-T-FC03B	2 /4 Pipe	BACnet	Fan 230V / 3 Steps Actuator 2x0...10V	NTC 10k N/O Occupancy Contact

Features

- » Manual or automatic 3-speed fan control
- » Proportional heating/cooling valves
- » Auto, Heat, Cool and Ventilation modes
- » Manual or automatic heating/cooling changeover
- » Fan Only, Heating and Fan, Cooling and Fan options
- » Universal input for external sensor or windows/energy saving contact etc.
- » Automatic heating/cooling changeover via changeover sensor
- » Automatic heating/cooling changeover via changeover contact
- » User setpoint limitation
- » Clock and time schedule functions
- » Key lock
- » Configurable user parameters
- » BACnet MS/TP communication
- » Modern styling and capacitive touch buttons
- » White backlight LCD
- » Different colour options; black and white
- » EU box flush-mount

Copyright by GRUNER AP @2024_V1. Subject to change in technology and Design.

Application

CRF9-T-FC03B Series Fan Coil Thermostats is used in individual rooms or zones in buildings. It is designed for two and four pipe fan coil units. CRF9-T-FC03B has one universal input as external sensor or open/close contact input, three relay outputs, two analogue outputs and one RS-485 port. It controls the fan coil unit depending on the internal room sensor or external return sensor temperature.

Notes of Usage

Notes on Usage Please, read this datasheet carefully. CRF9-T-FC03B thermostat is designed and manufactured in accordance with latest technological developments and safety. To avoid injury and property damage safety warnings must be observed.

Security Advice-Caution



Assembly, maintenance, and repair must be done by authorized service. The power supply of the device is 230 VAC/DC and it has no internal fuse. External protection with max C 10 A circuit breaker required in all cases. Disconnect from power supply before separating front plate.

Technical data

Electronic data

Power Supply	230 VAC 50/60 Hz
Power Consumption	Max ~3.0 VA
Electrical Connection	Terminal Connectors
Battery for Real Time Clock (RTC)	Lithium CR1220 3.3V
Measuring Range	-10°C ... +100°C (+14°F ... +212°F)
Resolution	0.1°C (1°F)
Inputs	1 Universal Input (NTC 10K or Dry Contact)
Outputs	3 Digital Outputs (3 x 5 (2) A Relay) 2 Analog Outputs (0-10V)
Communication	1 x RS-485 Port
Temperature Setting	5°C ... 99,9°C (Adjustable) (41°F ... 212°F (Adjustable))
Dimensions	86 x 86 x 52 mm
Mounting	Flush Mounted (Standard EU box)

Ordering Information

Product Code	Description	Power supply	Communication
CRF9-T-FC03B	3 Digital Outputs (Relay) Fan Control 2 Analog Outputs (0-10) Valve Control 1 Universal Input 1 RS-485 Port	230 VAC	BACnet MS/TP

Mounting Location



Thermostat is suggested to be installed indoors, a place with around 1.5m height above the floor so that it can measure the average room temperature. It should be away from direct sunlight, any cover or any heat source, to avoid false signal for temperature control.

CAUTION: Cut off the supply power at the circuit breaker or fuse before installation to avoid fire, shock or death!

Mounting Instructions

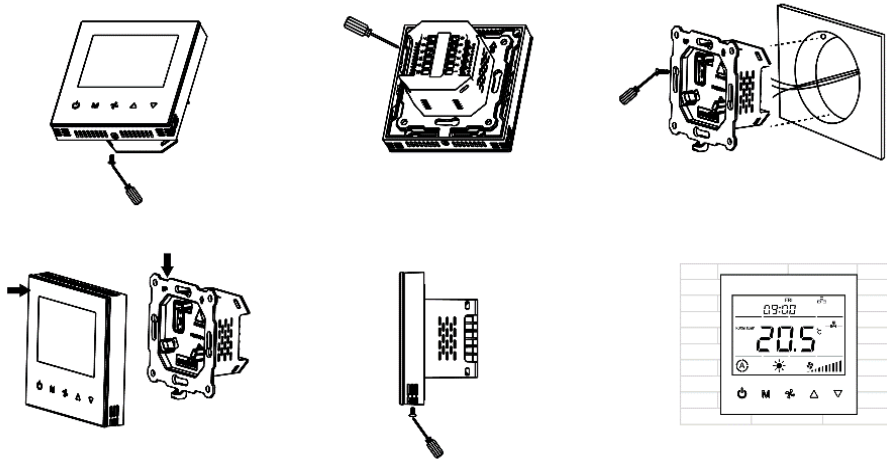

Please follow below instructions during mounting.

Step 1: Take the thermostat out from the package. Get the datasheet inside the package.

Step 2: Connect the wires properly according to the wiring diagram below.

Step 3: Separate the front plate and the back plate, and then use screwdriver to fix the back plate into the electric box with 4 screws.

Step 4: Attach the front plate to the back plate, making sure the pin plates on each side are well matched.

Step 5: Compare it with the pictures after installation.

Step 6: Power on the thermostat to work.

Important Note 1: It is recommended to use the following flush mount boxes for better mounting:

Alternative 1: Manufacturer: Viko by Panasonic, Part Number: 90926006 (Depth must be minimum 50 mm!)

Alternative 2: Manufacturer: Legrand, Part Number: 0 801 21 (Depth must be minimum 50 mm!)

Important Note 2: It is recommended to use the screws included in the product box. Otherwise, there could be fitting problems during the mounting.

Connection Diagrams

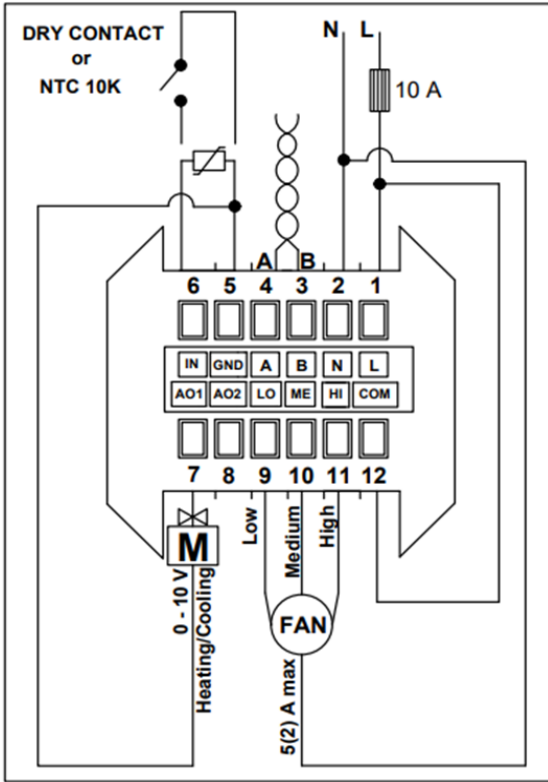

Connection Diagram for 2-Pipe Fan Coil

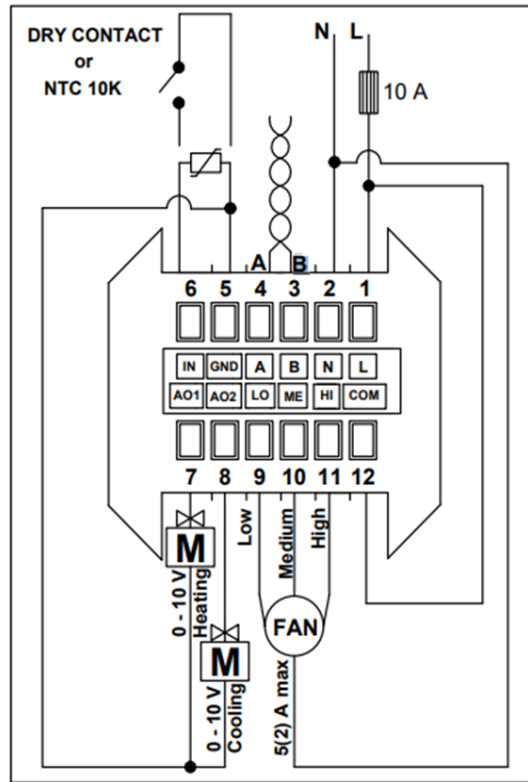

Connection Diagram for 4-Pipe Fan Coil

Note: Thermostat has no internal fuse. External protection with max C 10 A circuit breaker required in all cases. Isolate the cables of BACnet MS/TP communication inputs A, B from 230 V power supply.

Copyright by GRUNER AP @2024_V1. Subject to change in technology and Design.

Display and Operations

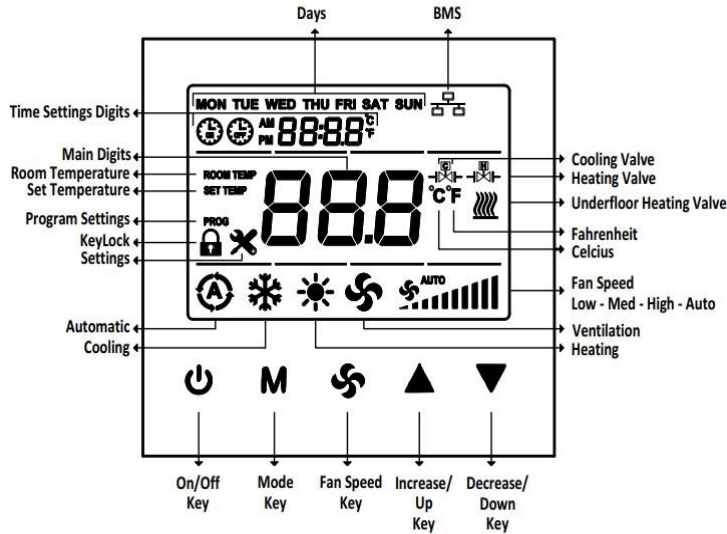

- **Mode Selection:** Press the “M” key to change the mode of the device. Active mode options are as follows.

	AUTOMATIC	COOL	HEAT	FAN
FAN ONLY	-	-	-	√
COOLING + FAN	-	√	-	√
2 PIPE SYSTEM	-	√	√	√
HEATING + FAN	-	-	√	√
4 PIPE SYSTEM	√	√	√	√

- **Fan Selection:** When the “” key is pressed, fan speed can be changed as Low, Med, High, Auto.
- **Time Settings:** After pressing the “M” key for 3 seconds, year digits flashes on the panel. “M” key is pressing once again, month digit flashes on the panel. “M” key is pressed once again, day digit flashes on the panel. “M” key is pressed once again, hour digit flashes on the panel. “M” key is pressed once again, minute digit flashes on the panel. “M” key is pressed once again, day of week digit flashes on the panel. Year, month, day, hour, minute, day of week information are be changed by “▲” and “▼” keys.

Order: Year -> Month -> Day -> Hour -> Minute -> Day Of Week

- **Schedule Operations:** Be sure to set the time settings, before making schedule operations. After setting the day, to enter the Schedule menu, press the “M” key one time. While in the Schedule menu, “Monday opening time hour digit” flashes on the panel. When the “M” key is pressed once again, “Monday opening time minute digit” flashes on the panel. Then, when the “M” key is pressed one more time, “Monday closing time hour digit” flashes on the panel. After that when the “M” key is pressed once again, “Monday closing time minute digit” flashes on the panel. While the digits flashing, hour and minute can be changed by “▲” and “▼” keys. Use the “M” key to set the other days’ schedule.

Note: When the time schedule is set, the on/off lock will be activated.

- **Key Lock Operations:** Pressing both “M” and “▲” key, key lock digit displays on the panel. The panel is locked. When the panel is locked, press the “M” and “▲” keys to unlock panel. “Key Lock” options can be changed via parameter P6. To lock two or more keys at the same time; sum the numbers of the keys. To lock mode key and on/off key, 1 (on/off) and 2 (mode) should be added and written 3 to parameter P6. To lock setpoint and fan speed, 4 (setpoint) and 8 (fan speed) should be added and written 12 to parameter P6

Copyright by GRUNER AP @2024_V1. Subject to change in technology and Design.

Configuration

Configuration Menu Description

When the device on or off position, press together “Main Parameter Increase Key” (M) and “Value Decrease Key” (▼) for 3 seconds, to enter the Configuration Menu. In the password screen, Password digits can be changed by “Main Parameter Increase Key” (M), Password value can be changed by “Value Increase Key” (▲) and “Value Decrease Key” (▼). Password must be entered as “203” and “Main Parameter Decrease Key” (⊗) must be pressed to confirm. When the correct password is written, the configuration menu will be entered. If the wrong password is entered, it will fail, and the password will reset. Password screen will return to main screen without any action 10 seconds. Parameter setting screen will return to main screen without any action in 30 seconds. All parameters are stored within device memory ensuring no data loss if the Thermostat is powered off.

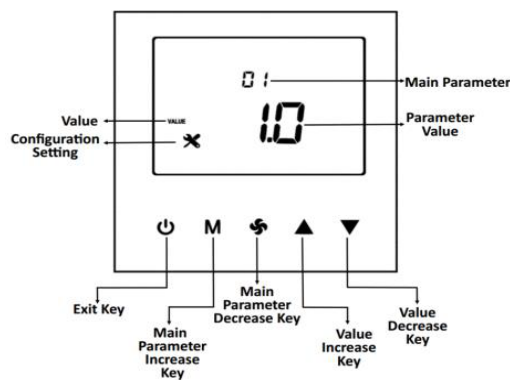

Universal Input (Parameter P32 or Via BACnet)

Universal Input (Parameter P32 or via BACnet)

- External Sensor for room (parameter P32 = 1)

The device operates according to external temperature sensor value read from the universal input.

- External Sensor (parameter P32 = 2)

The device operates according to internal temperature sensor value. The temperature read from the universal input can be monitored from P36 and related BMS point.

- Changeover sensor (parameter P32 = 3)

If “Universal Input” value is selected as changeover, “dead zone” cannot be used.

Changeover sensor only valid when “Fan Coil Type” is set to 2.

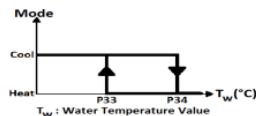

When the water temperature is above **P34** the thermostat changes over to heating mode. It stays in heating mode until the temperature falls below **P33**.

When the water temperature is below **P33**, the thermostat changes over to cooling mode. It stays in cooling mode until the temperature rises above **P34**.

- Changeover contact-On/Off (NC Contact) (parameter P32 = 4)

Changeover sensor only valid when “Fan Coil Type” is set to 2.

When this contact is closed, the device will operate according to the cooling mode. When the contact is opened, it will operate according to the heating mode.

- Changeover contact-Off/On (NO Contact) (parameter P32 = 5)

Changeover sensor only valid when “Fan Coil Type” is set to 2.

When this contact is opened, the device will operate according to the cooling mode. When the contact is closed, it will operate according to the heating mode.

- Windows contact/Energy saving-On/Off (NC Contact) (parameter P32 = 6)

When this contact is closed, the device is in the “ON” position. When this condition is not met, the device shows “OPEN” on the panel and the outputs of the device are passive.

- Windows contact/Energy saving-Off/On (NO Contact) (parameter P32 = 7)

When this contact is opened, the device is in the “ON” position. When this condition is not met, the device shows “OPEN” on the panel and the outputs of the device are passive.

Hysteresis (Parameter P40 or via BACnet)

The output diagram of the valve according to the relation between T_S and T_R is given below.

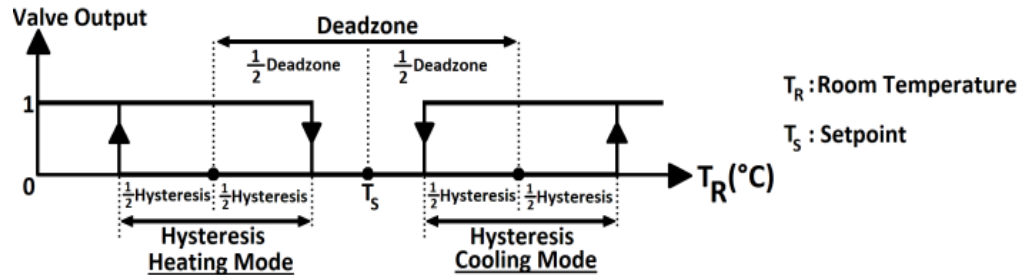

Fan/Valve Control Selection (Parameter P41 or via BACnet)

In valve independent mode, the fan operates according to manual fan selection or automatic fan control. When valve is closed, the fan will continue to operate.

In valve dependent mode, the fan will be closed when the valve is closed. If the valve is open, the fan will operate according to manual fan selection or automatic fan control.

Restore Factory Setting (Parameter P45 or via BACnet)

The device can load the factory setting parameters via parameter P45, by changing the value to "1", and pressing button "Exit Key". While in the factory reset process, lines on the top and the bottom will be running from left to right for 3 seconds. The display shows top and bottom lines loaded step by step during reload process approximately 3 seconds.

Alarms

Alarm Code will appear on the screen, during alarm, if one of the alarm conditions is met. Alarm Codes will appear on the screen alternately. If more than one alarm condition is met.

- Onboard Sensor Alarm:

If the internal temperature sensor fails, "AL 01" will appear on the screen and "Err" will be shown on the main digits. During the alarm, device outputs will be closed. If the "Universal Input" is selected to "External Sensor", the device continues normal operation.

- External Sensor Alarm:

If the "Universal Input" parameter is set to "External Temperature Sensor" and sensor is not connected or connection breaks down, "AL 02" will appear on the screen and "Err" will be shown on the main digits. During the alarm, device outputs will be closed. "Universal Input" is set to "Not Used" to eliminate the alarm.

- Changeover Sensor Alarm:

If the "Universal Input" is selected to "Change over Sensor" also the sensor is broken down, displayed "AL 03" on the panel and "Err" on the Main Digits. During the alarm, device outputs will be closed. "Universal Input" is set to "Not Used" to eliminate the alarm.

Configuration Menu Parameters

No.	Name of Parameter	Parameter Definition	Factory Default
P1	Hardware Version	Device hardware version	2.0
P2	Firmware Version	Device firmware version	1.4
P3	Setpoint High Limit	Range: Set Point Low Limit ... 99.9°C (Range: 41°F ... 212°F)	30°C (86°F)
P4	Setpoint Low Limit	Range: 5°C ... Set Point High Limit (Range: 41°F ... 86°F)	5°C (41°F)
P5	Main Screen	0 = Room temperature 1 = Setpoint temperature 2 = Room Temperature and Setpoint Temperature alternate	0
P6	Key Lock	0 = Unlocked 1 = Lock On/Off 2 = Lock Mode 4 = Lock Setpoint 8 = Lock Fan Speed 16 = Lock Time Settings 32 = Lock Time Schedule Settings 63 = Locked All (* To lock two or more keys at the same time; sum the numbers of the keys. To lock setpoint and fan speed, 4 (Setpoint) and 8 (Fan Speed) should be added and written 12.	0
P7	Celsius or Fahrenheit	0 = Celsius 1 = Fahrenheit	0
P8	Time Format	0 = 24 hours clock 1 = 12 hours clock (AM/PM) (* The system Time Format is 24 hours. This parameter adjusts how the clock format on the panel/screen will be shown	1
P9	Time Schedule Enable	0 = Disable 1 = Enable	0
P10	Screen Saver	0 = Screen Saver Disabled 1 = Display On 2 = Display Off 3 = Main Screen Temperature 4 = Main Screen and Clock 5 = Room Temperature and Setpoint alternately, and Clock (* When the Main Screen parameter is set to "2", Room Temperature appears instead of Main Screen at the 3. and 4. parameters	4
P11	Screen Saver Mode Delay	Range: 10 ... 150 seconds	60 sec.
P12	LCD Brightness	Range: 1 ... 5 stages	5
P13	Buzzer Stage	Range: 0 ... 5 stages	3
P14	Power Failure	This parameter adjusts the condition that the device will continue when the power failure happens. 0 = Device starts off 1 = Device starts on 2 = Keep State Before Power Failure	2
P15	Screen Off State Status	0: Screen off 1: Room Temperature 2: Room Temperature and Off 3: Room Temperature and Clock	1
P16	Valve Proportional Band	This parameter determines proportionally the output value of the valve depending on the difference between Room Temperature and Set Point. Range: 1 ... 100 => 0.1°C ... 10°C	20
P17 ... P24	Reserved	-	-

P25	Valve Minimum Value	It determines the minimum value of the valve outputs. 0 ... 100 => 0V ... 10V	0
P26	Valve Maximum Value	It determines the maximum value of the valve outputs. 0 ... 100 => 0V ... 10V	100
P27	Underfloor Heating Activation	0 = Underfloor Heating Disable 1 = Underfloor Heating Enable	0
P28	Heating Valve Direction	0 = Normal Direct 1 = Reverse Direct	0
P29	Cooling Valve Direction	0 = Normal Direct 1 = Reverse Direct	0
P30	Fan Coil Type	0 = Fan Only 1 = 2 pipe system Cooling + Fan 2 = 2 pipe system 3 = 2 pipe system Heating + Fan 4 = 4 pipe system	4
P31	Internal Temperature Sensor Calibration	Range: -10°C ... 10°C and 0.1°C steps (Range: -18°F ... 18°F and 1°F steps)	0°C (0°F)
P32	Universal Input	0 = Not used 1 = External Temperature sensor for room (NTC 10K) 2 = External Temperature sensor (NTC 10K) (Monitoring purpose) 3 = Changeover sensor (NTC 10K) 4 = Changeover contact-On/Off (NC Contact) 5 = Changeover contact-Off/On (NO Contact) 6 = Windows contact/Energy saving-On/Off (NC Contact) 7 = Windows contact/Energy saving-Off/On (NO Contact)	0
P33	Changeover Temperature for Cooling	Range: 10°C ... 25°C. Only valid when P32 is set to 3 (Range: 50°F ... 77°F. Only valid when P32 is set to 3)	16°C (60°F)
P34	Changeover Temperature for Heating	Range: 26°C ... 45°C. Only valid when P32 is set to 3 (Range: 78°F ... 113°F. Only valid when P32 is set to 3)	28°C (82°F)
P35	Mode Change Delay	Range: 0 ... 255 minutes	3 min.
P36	Universal Input Temperature	If P32 is "1", "2" or "3", this parameter shows the sensor temperature.	0°C (0°F)
P37	Universal Input Temperature Calibration	Range: -10°C ... 10°C and 0.1°C steps (Range: -18°F ... 18°F and 1°F steps)	0°C (0°F)
P38	Auto Mode Enable	0 = Disable (Only valid when P30 is set to 4) 1 = Enable	1
P39	Dead Zone	Range: 0°C ... 15°C. Only valid when P38 is set to 1 (Range: 0°F ... 27°F. Only valid when P38 is set to 1)	2°C (3°F)
P40	Hysteresis	Range: 0°C ... 15°C (Range: 0°F ... 27°F)	1°C (1°F)
P41	Fan/Valve Control Selection	0 = Valve independent 1 = Valve dependent	1
P42	Fan Stage Change Delay	Range: 0 ... 5 seconds	2 sec.
P43	Fan Off Delay	Range: 0 ... 60 seconds	0 sec.
P44	BMS Icon Enable	0 = Disable 1 = Enable	1
P45	Restore Factory Setting	0 = Factory Setting Disable 1 = Factory Setting Started	0
P46	Baudrate	1 = 9600bps 3 = 38400bps 2 = 19200bps 4 = 76800bps	4
P47	Loop ID	Range: 00 ... 04	0
P48	BACnet MAC Address	Range: 001 ... 127	1
P49	Parameter Menu Password	Range: 001 ... 999 (Read Only)	203

BACnet Parameters

According to BACnet standards, MSTP port configurations are as follows;
-8 Data Bits, None Parity, 1 Stop Bit

MAC Address: 1 ... 127. Default 1

Baudrate : 9600, 19200, 38400, 76800. Default 76800

Note 1: The MAC address can be changed via configuration menu.

Note 2: Device Instance Number (Device ID) is automatically calculated as below.

$$\text{Device ID} = 856 * 1000 + \text{Loop ID} * 200 + \text{MAC}$$

For example: Mac: 13, Loop ID: 1 => Device ID = 856 * 1000 + 1 * 200+ 13 = 856213

When the MAC address is changed via configuration menu, the Device ID is automatically recalculated to avoid network ID conflict.

As a property of Device Object, Device ID value is writable via BACnet between 0 and 4194302. Once the Device ID is changed via BACnet, Device ID automatic calculation mentioned above is ineffective.

End of Line (EOL) Resistor

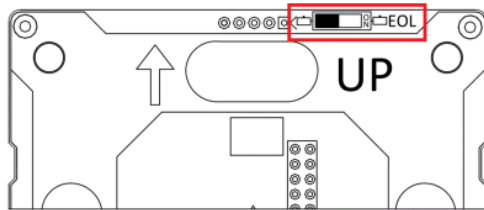

When the thermostat front plate is flipped, the EOL resistor DIP switch is seen on the upper right side of the back plate. This resistor's default position is OFF. When the End of Line (EOL) resistor is needed to be used, DIP Switch position should be switched to ON.

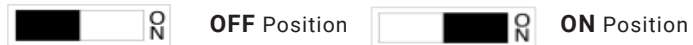

CRF9-T-FC03B BACnet Object List

No.	Object	Value	Object Name	Function	Default	Read (R)/ Write (W)
Analog Inputs						
1	Analog Input #1	-9.9°C ... 99.9°C (14.1°F ...211.8°F)	Room Temperature	This parameter shows the room temperature value.	-	R
2	Analog Input #2	-9.9°C ... 99.9°C (14.1°F ... 211.8°F)	Universal Input Temperature	If "Universal Input" is "1", "2" or "3", this parameter shows the sensor temperature.	-	R
Analog Values						
3	Analog Value #1	0 ... 3	Mode	0 = Fan Only 1 = Heat 2 = Cool 3 = Auto	3	R/W
4	Analog Value #2	1 ... 4	Fan Speed	1 = Low 2 = Med 3 = High 4 = Auto	1	R/W
5	Analog Value #3	Set Point Low Limit ... Set Point High Limit	Set Point	This parameter is the desired room temperature value.	21°C (69.8°F)	R/W
6	Analog Value #4	Set Point Low Limit ... 99.9°C (41°F ... 212°F)	Set Point High Limit	This parameter adjusts the high limit for desired room temperature.	30°C (86°F)	R/W

Copyright by GRUNER AP @2024_V1. Subject to change in technology and Design.

7	Analog Value #5	5°C ... Set Point High Limit (41°F ... 86°F)	Set Point Low Limit	This parameter adjusts the low limit for desired room temperature.	5°C (41°F)	R/W
8	Analog Value #6	0 ... 63	Key Lock	0 = Unlocked 1 = Lock On/Off 2 = Lock Mode 4 = Lock Setpoint 8 = Lock Fan Speed 16 = Lock Time Settings 32 = Lock Time Schedule Settings 63 = Locked All (* To lock two or more keys at the same time; sum the numbers of the keys. To lock setpoint and fan speed, 4 (Setpoint) and 8 (Fan Speed) should be added and written 12.	0	R/W
9	Analog Value #7	0 ... 2	Power Failure	This parameter adjusts the condition that the device will continue when the power failure happens. 0 = Device starts off 1 = Device starts on 2 = Keep State Before Power Failure	2	R/W
10	Analog Value #8	0 ... 4	Fan Coil Type	0 = Fan Only 1 = 2 pipe system Cooling +Fan 2 = 2 pipe system 3 = 2 pipe system Heating +Fan 4 = 4 pipe system	4	R/W
11	Analog Value #9	-10°C ... 10°C (-18°F ... 18°F)	Internal Temperature Sensor Calibration		0°C (0°F)	R/W
12	Analog Value #10	0 ... 7	Universal Input	0 = Not used 1 = External Temperature sensor for room (NTC 10K) 2 = External Temperature sensor (NTC 10K) (Monitoring purpose) 3 = Changeover sensor (NTC 10K) 4 = Changeover contact- On/Off (NC Contact) 5 = Changeover contact- Off/On (NO Contact) 6 = Windows contact/Energy saving- On/Off (NC Contact) 7 = Windows contact/Energy saving- Off/On (NO Contact)	0	R/W
13	Analog Value #11	10°C ... 25°C (50°F ... 77°F)	Changeover Temperature for Cooling	If "Universal Input" is set to "3", this parameter adjusts changeover temperature for cooling mode.	16°C (60.8°F)	R/W
14	Analog Value #12	26°C ... 45°C (78.8°F ... 113°F)	Changeover Temperature for Heating	If "Universal Input" is set to "3", this parameter adjusts changeover temperature for heating mode.	28°C (82.4°F)	R/W
15	Analog Value #13	0 min. ... 255 min.	Mode Change Delay	This parameter adjusts delay time between heat and cool modes.	3 min.	R/W

16	Analog Value #14	-10°C ... 10°C (-18°F ... 18°F)	Universal Input Temperature Calibration		0°C (0°F)	R/W
17	Analog Value #15	0°C ... 15°C (0°F ... 27°F)	Dead Zone	If "Mode" is set to "Auto", this parameter adjusts dead zone.	2°C (3.6°F)	R/W
18	Analog Value #16	0°C ... 15°C (0°F ... 27°F)	Hysteresis	This parameter adjusts hysteresis.	1°C (1.8°F)	R/W
19	Analog Value #17	0 sec. ... 5 sec.	Fan Stage Change Delay	This parameter adjusts delay of the changing range the fan.	2 sec.	R/W
20	Analog Value #18	0 sec. ... 60 sec.	Fan Off Delay	This parameter adjusts delay of the closing time the fan.	0 sec.	R/W
21	Analog Value #19	0 ... 3	Fan Status	0 = Off 2 = Med 1 = Low 3 = High	0	R
22	Analog Value #20	1 ... 100	Valve Proportional Band	This parameter determines proportionally the output value of the fan depending on the difference between Room Temperature and Set Point. Range: 0.1°C ... 10°C	20	R/W
23	Analog Value #21	0 ... 100	VA1 State	0V .. 10V => 0 ... 100	0	O
24	Analog Value #22	0 ... 100	VA2 State	0V .. 10V => 0 ... 100	0	O
25	Analog Value #23	0 ... 3	Alarm	This parameter indicates the alarm state. 0 = No alarm 1 = Onboard Sensor Alarm 2 = External Sensor Alarm 3 = Changeover Sensor Alarm	0	R
26	Analog Value #24	0...2359	Monday Start Time	The hour and minute value written in this parameter are set to turn on the device on Monday.	0	R/W
27	Analog Value #25	0...2359	Monday Stop Time	The hour and minute value written in this parameter are set to turn off the device on Monday.	0	R/W
28	Analog Value #26	0...2359	Tuesday Start Time	The hour and minute value written in this parameter are set to turn on the device on Tuesday.	0	R/W
29	Analog Value #27	0...2359	Tuesday Stop Time	The hour and minute value written in this parameter are set to turn off the device on Tuesday.	0	R/W
30	Analog Value #28	0...2359	Wednesday Start Time	The hour and minute value written in this parameter are set to turn on the device on Wednesday.	0	R/W
31	Analog Value #29	0...2359	Wednesday Stop Time	The hour and minute value written in this parameter are set to turn off the device on Wednesday.	0	R/W
32	Analog Value #30	0...2359	Thursday Start Time	The hour and minute value written in this parameter are set to turn on the device on Thursday.	0	R/W

33	Analog Value #31	0...2359	Thursday Stop Time	The hour and minute value written in this parameter are set to turn off the device on Thursday.	0	R/W
34	Analog Value #32	0...2359	Friday Start Time	The hour and minute value written in this parameter are set to turn on the device on Friday.	0	R/W
35	Analog Value #33	0...2359	Friday Stop Time	The hour and minute value written in this parameter are set to turn off the device on Friday.	0	R/W
36	Analog Value #34	0...2359	Saturday Start Time	The hour and minute value written in this parameter are set to turn on the device on Saturday.	0	R/W
37	Analog Value #35	0...2359	Saturday Stop Time	The hour and minute value written in this parameter are set to turn off the device on Saturday.	0	R/W
38	Analog Value #36	0...2359	Sunday Start Time	The hour and minute value written in this parameter are set to turn on the device on Sunday.	0	R/W
39	Analog Value #37	0...2359	Sunday Stop Time	The hour and minute value written in this parameter are set to turn off the device on Sunday.	0	R/W
40	Analog Value #38	2017 ...2099	Current Year	This parameter adjusts the current year.	2023	R/W
41	Analog Value #39	1 ... 12	Current Month	This parameter adjusts the current month.	-	R/W
42	Analog Value #40	1 ... 31	Current Day	This parameter adjusts the current day.	-	R/W
43	Analog Value #41	00 ... 23	Current Hour	This parameter adjusts the current hour.	-	R/W
44	Analog Value #42	00 ... 59	Current Minute	This parameter adjusts the current minute.	-	R/W
45	Analog Value #43	1 ... 4	Baudrate	1 = 9600bps 2 = 19200bps 3 = 38400bps 4 = 76800bps	4	R/W
46	Analog Value #44	1 ... 999	Parameter Menu Password	This parameter sets the parameter menu password.	203	R/W
47	Analog Value #45	0 ... 100	Valve Minimum Value	It determines the minimum value of the valve outputs. 0 ... 100 => 0V ... 10V	0	R/W
48	Analog Value #46	0 ... 100	Valve Maximum Value	It determines the maximum value of the valve outputs. 0 ... 100 => 0V ... 10V	100	R/W
Binary Inputs						
49	Binary Input #1	0 ... 1	Universal Input Digital Input Value	0 = Off 1 = On	-	R
Binary Values						

50	Binary Value #1	0 ... 1	Start/Stop	0 = Stop 1 = Start	1	R/W
51	Binary Value #2	0 ... 1	Celsius or Fahrenheit	0 = Celsius 1 = Fahrenheit	0	R/W
52	Binary Value #3	0 ... 1	Auto Mode Enable	0 = Disable 1 = Enable	1	R/W
53	Binary Value #4	0 ... 1	Fan/Valve Control Selection	0 = Valve Independent 1 = Valve Dependent	1	R/W
54	Binary Value #5	0 ... 1	Restore Factory Setting	0 = Factory Setting Disable 1 = Factory Setting Started	0	R/W
55	Binary Value #6	0 ... 1	Time Schedule Local and Remote Selection	0 = Time Schedule Local Selected 1 = Time Schedule Remote Selected	0	R/W
56	Binary Value #7	0 ... 1	Heating Valve Direction	0 = Normal Direct 1 = Reverse Direct	0	R/W
57	Binary Value #8	0 ... 1	Cooling Valve Direction	0 = Normal Direct 1 = Reverse Direct	0	R/W
58	Binary Value #9	0 ... 1	Underfloor Heating Activation	0 = Underfloor Heating Disable 1 = Underfloor Heating Enable	0	R/W

Dimensions(mm)

